

Manual with instalation proces 8HP45 tranmissions on
Mazda Miata MX5 BP 1.8 and NB B6 1.6 engine

E-mail: adamat@poczta.onet.eu

List of compatibble tranmission

BMW ZF 8HP 8HP45 GA8HP45 BMW N20 N26

After flywheel change fit also:

BMW ZF 8HP 8HP45 GA8HP45 BMW N55

BMW ZF 8HP 8HP45R GA8HP45R BMW S55

1. Main flywheel installation guide.

Torque for 6 bolts from kit M12x1

Please ensure that bolts from kit have correct length in crankshaft.

- use lubricant soft threadlocker
- first stage 49Nm
- Second stage 71Nm
- final stage 96-102Nm

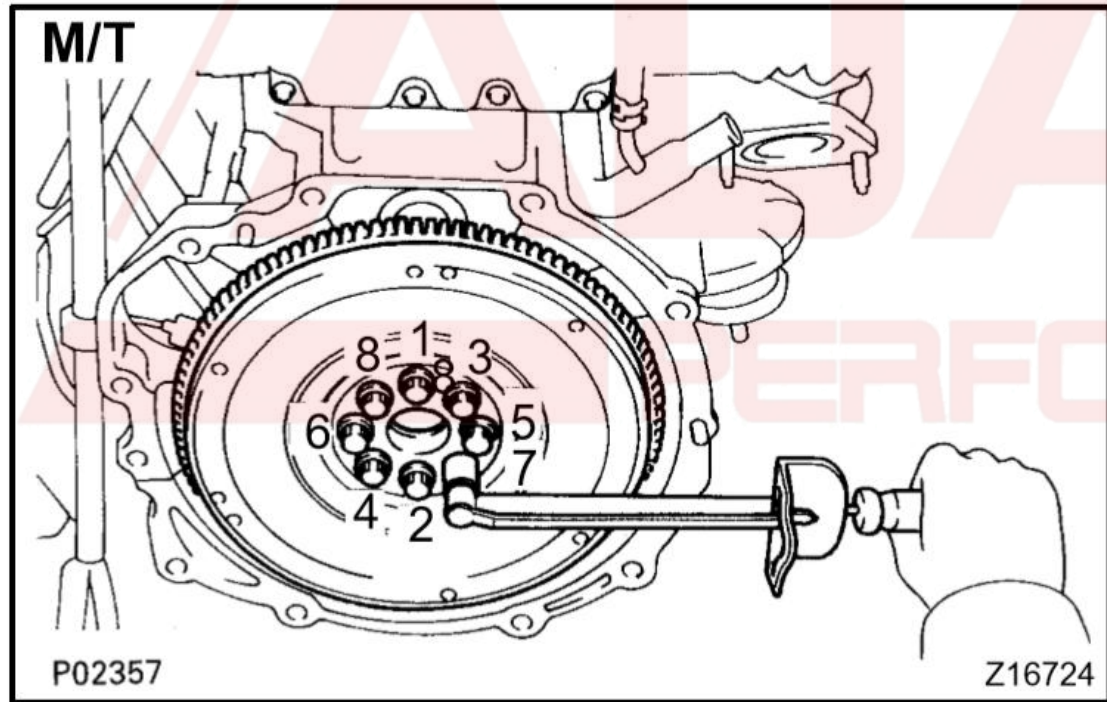

2. Before adapter plate installation, please put adapter on transmission and mark on transmission area for local modification. In transmission case. Its necessary to get free space for starter motor case.

Full grey color are 8HP trans case shape.

Example marked area for local modification.

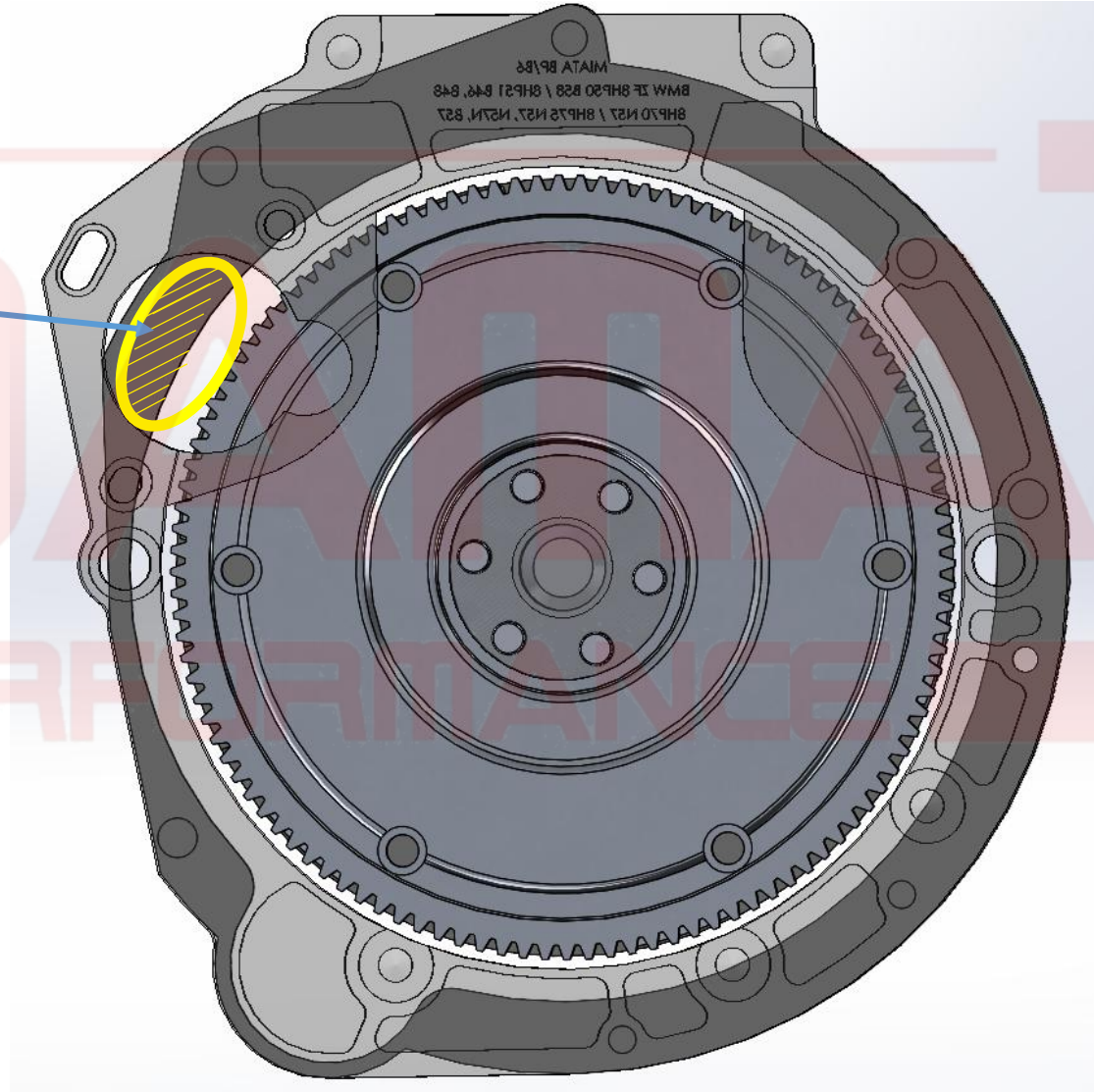

3. Adapter plate fitment on engine

No	DIN912 size	pcs
1	DIN6921 M12x1,5x30	5
2	DIN6921 M12x1,5x50	2
3	DIN912 M10x25 Assembled from opposite directly by starter motor	3

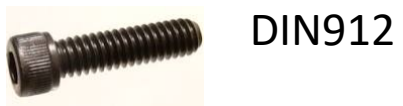
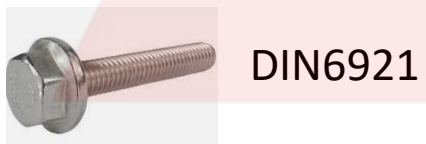

4 . Tranmission installation bolts chart 8HP45 N20 / N26 N55 / S55

No	DIN912 size	pcs
1	M12x1,5x40	1
3	M10x55	4
4	M12x1,5x55	2
5	M8x45	3
4	14,5 Dowels installed in adapter	2

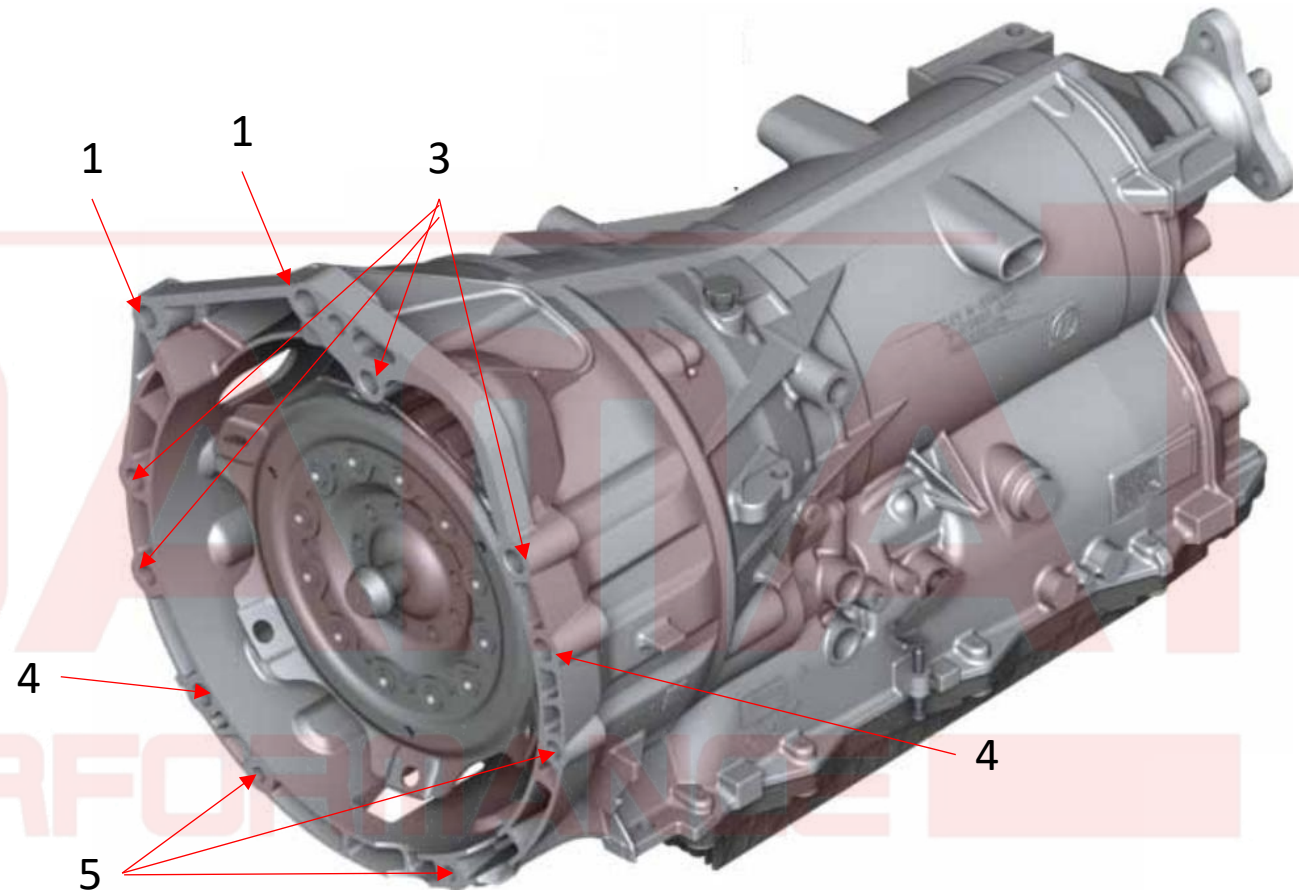

5A. Assy transmission with torque converter on engine bolts chart for 8HP45 N20 – N26.



Revision hole in 8HP45 N20
N26 for Torque bolts assy

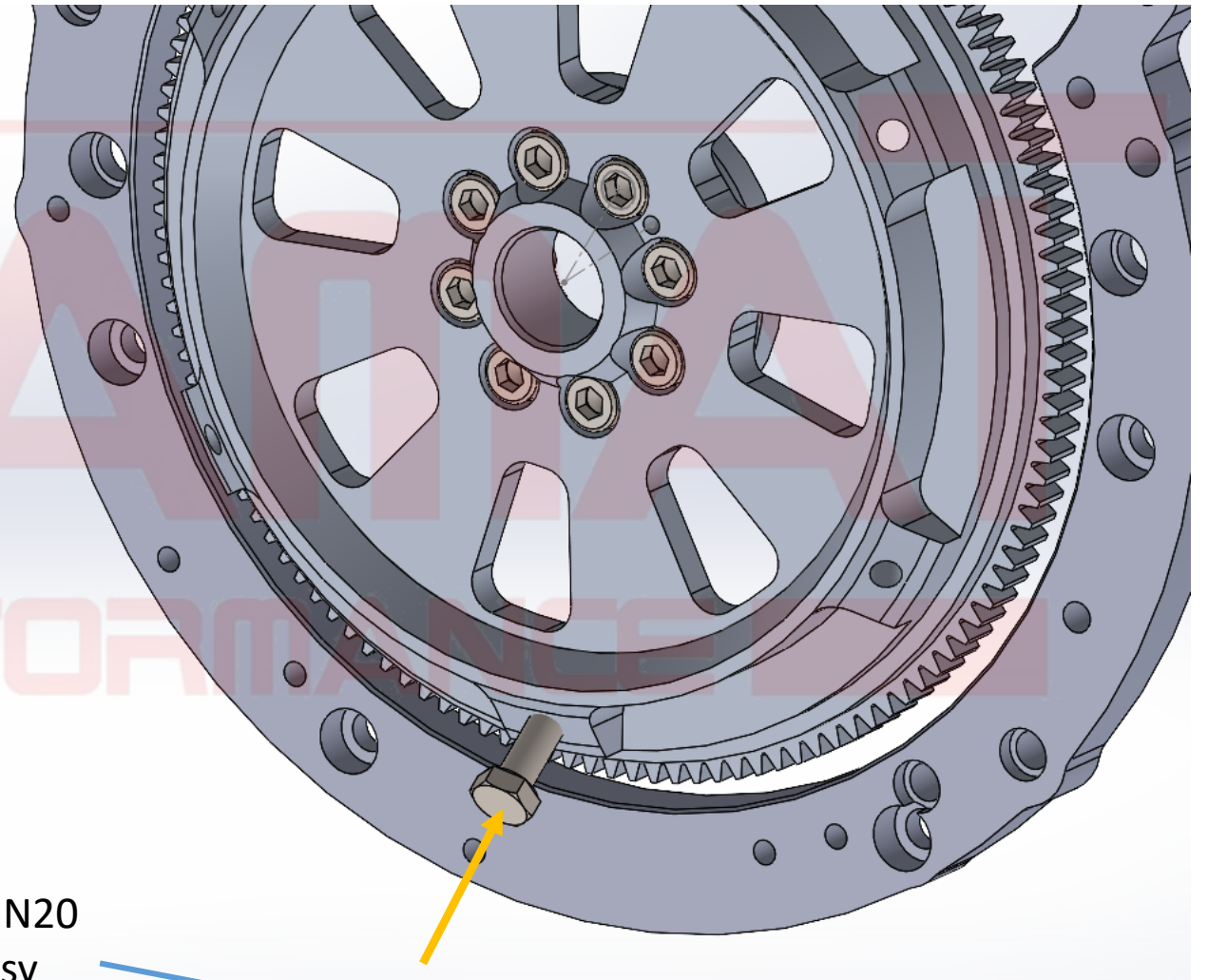

6 bolts DIN 931 10.9 class
M10x20 final torque 79Nm

5B. Torque converter to main flywheel fitment.

2 Torque for 6x bolts DIN912 M10x25 12.9class

- first stage 49Nm
- Secound stage 55Nm
- final stage 79Nm



DIN912

Hole in adapter
for bolts
installation.

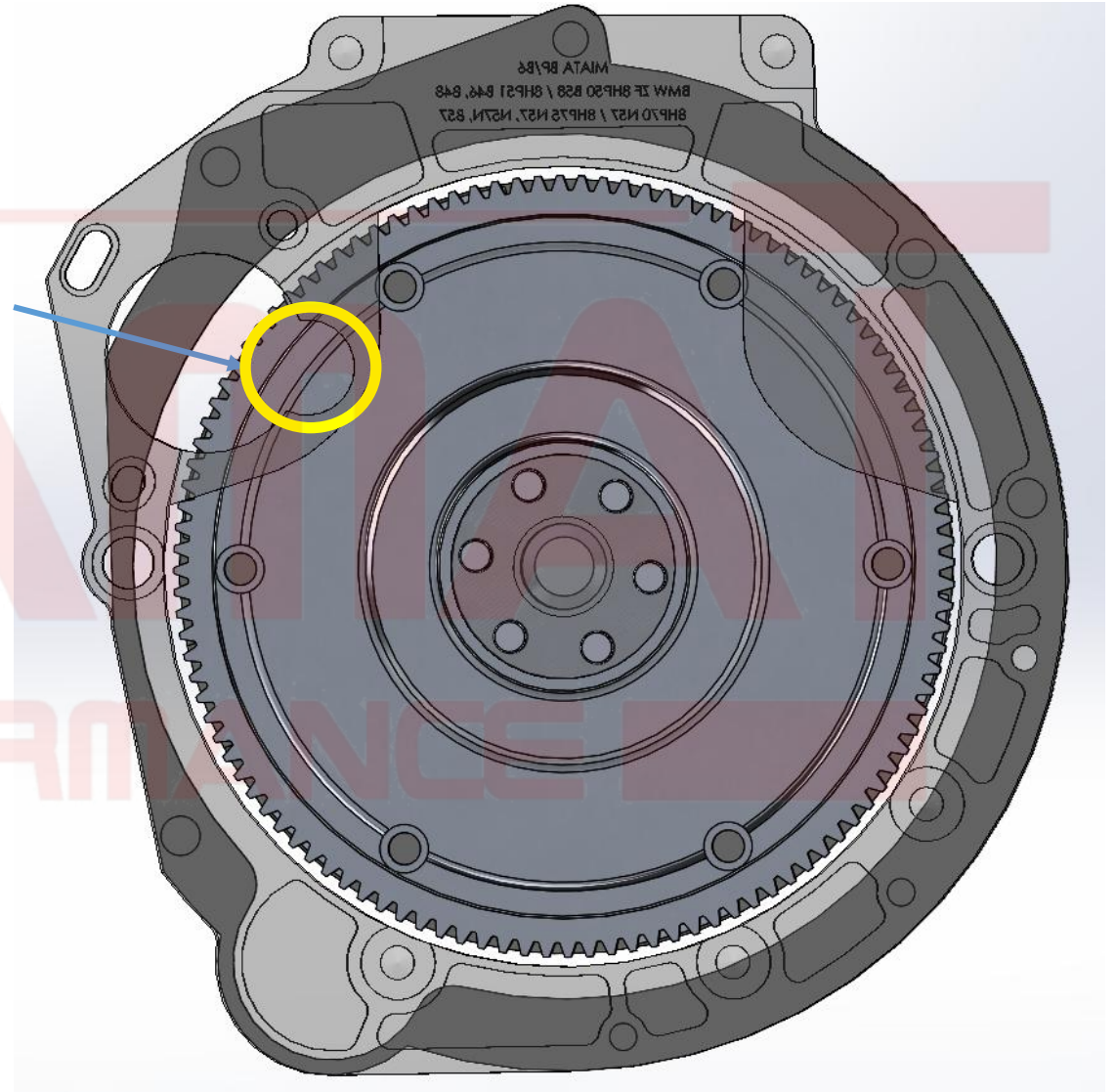

7. In final step please install starter motor using 3 bolts DIN912 M10x25 .